

SPECIALS

VACUUM COLD PLATES

(For applications utilizing plate type evaporators—zinc finish or stainless steel)

Liquid cooling equipment for photo processing solutions,
industrial coolants, dry cleaning fluids, etc.

Food service, display and storage cases.

Food and ice vending machines.

Ice building and storage units.

Low temperature test cabinets.

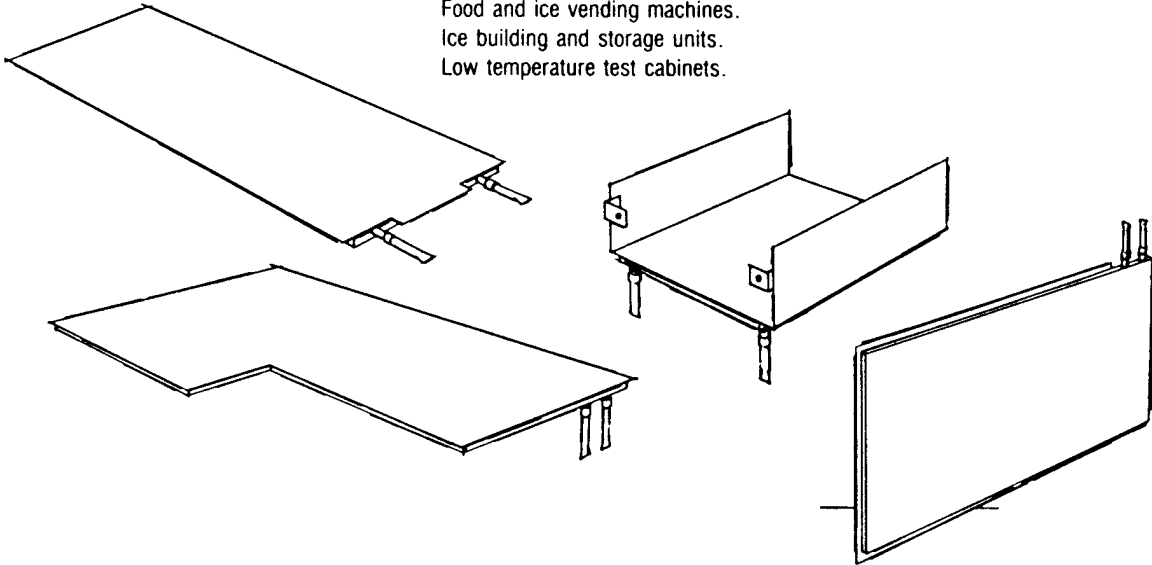

EUTECTIC HOLDOVER PLATES

(For applications where continuous compressor operations is not available)

Mobile food service carts.

Portable vending cabinets and island merchandisers.

Catering trucks.

Shipping and delivery containers.

Camper, trailer and boat refrigerators.

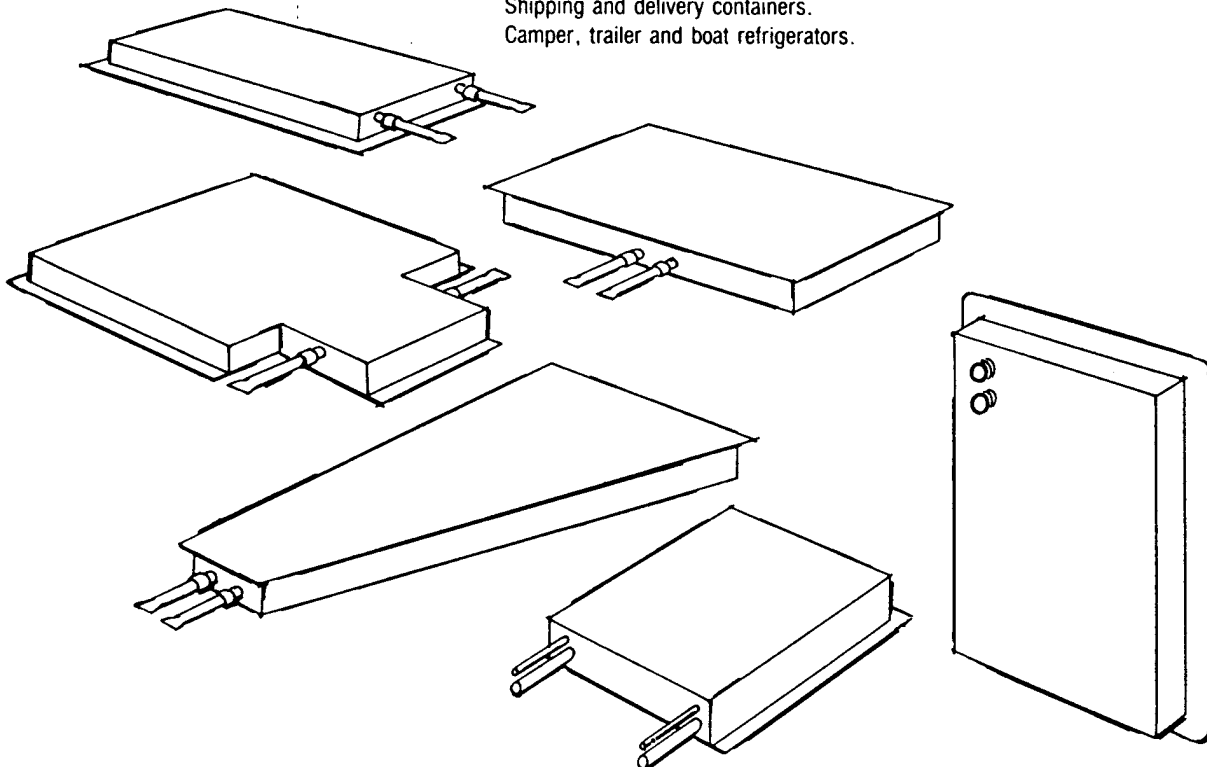



EXTRUDED ALUMINUM PLATES

(For applications requiring a maximum rate of heat transfer)

- Double contact food freezers.
- Liquid chilling.
- Ice cream hardening room shelves.
- Cooling tunnels.
- Chilling conveyors.
- Heat-sealed packaging equipment.
- Plastic film processing.

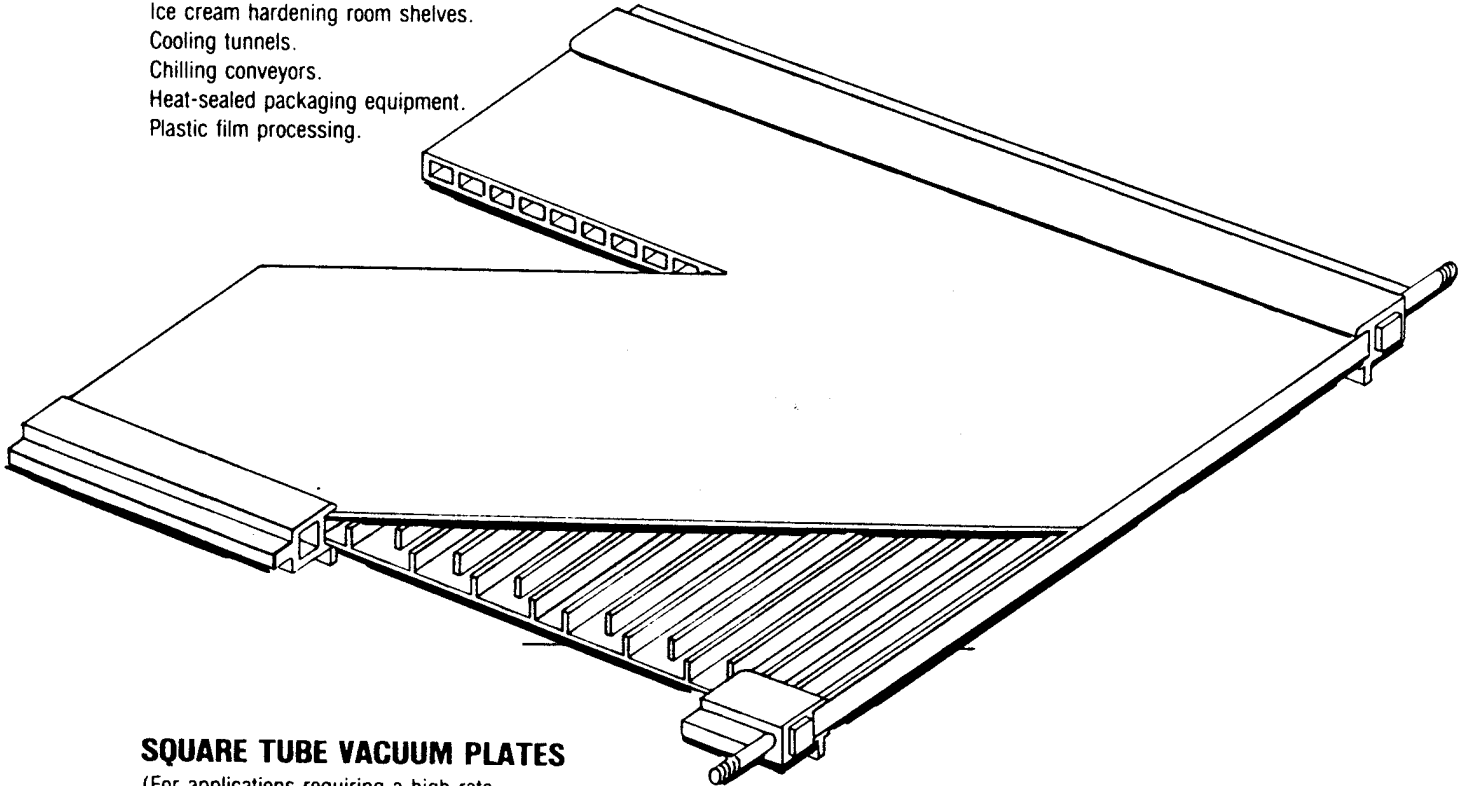

SQUARE TUBE VACUUM PLATES

(For applications requiring a high rate of heat transfer)

- Double contact food freezers.
- Ice cream hardening room shelves.
- Cooling tunnels.
- Chilling conveyors.
- Plastic film processing.

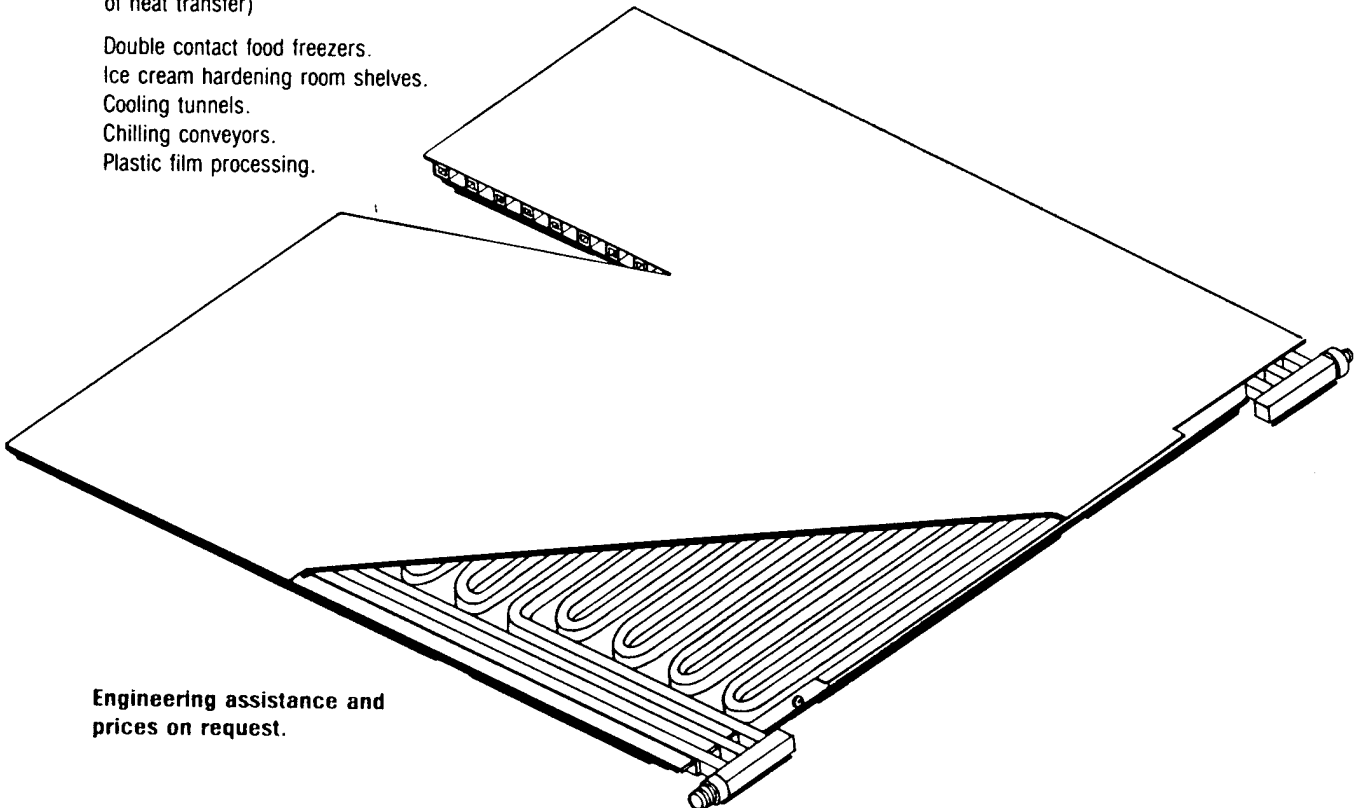

Engineering assistance and prices on request.

DOLE REFRIGERATING CO.

1420 HIGGS ROAD
LEWISBURG, TENNESSEE 37091

SPECIAL PLATE SPECIFICATIONS

CUSTOMER _____

PO# _____

ADDRESS _____

DATE _____

DIMENSIONS:

L = LENGTH

W = WIDTH

MATERIAL:

*MILD STEEL ZINC METALLIZED

PAINT FINISH

STAINLESS STEEL 100 GRIT FINISH

OTHER _____

CONNECTIONS:

* $\frac{5}{8}$ " COPPER (FREON)

$\frac{1}{2}$ " FEMALE PIPE (AMMONIA)

OTHER _____

INTERNAL TUBING:

* $\frac{5}{8}$ " O.D. STEEL ($\frac{3}{4}$ " THICK PLATE)

OTHER _____

EUTECTIC SOLUTION:

*NONE *+26° (SALAD PLATES)

 +18° 0° -9°

-12° -18°

LOCATION OF FITTINGS:

(SEE SKETCHES ON BACK)

*FITTINGS PER SKETCH

FITTINGS PER SKETCH

*INDICATES STANDARD WILL BE FURNISHED UNLESS OTHERWISE SPECIFIED

IMPORTANT

IF PLATE(S) IS FOR VERTICAL MOUNTING INDICATE TOP.

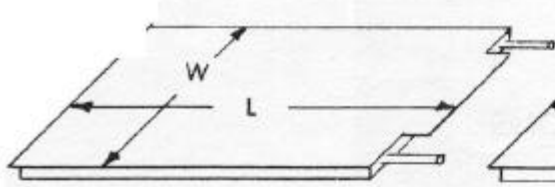

A

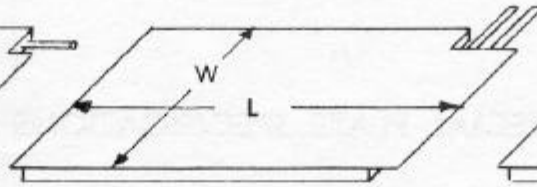

B

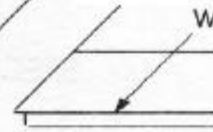

C

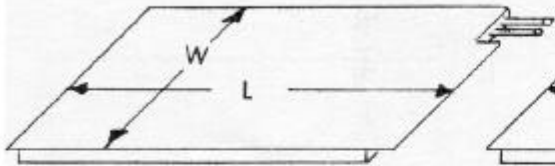

D

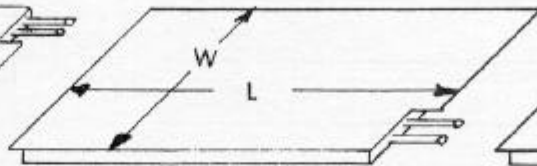

E

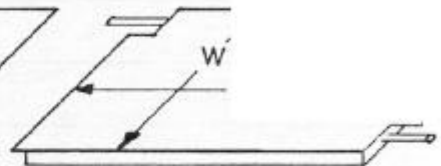

F

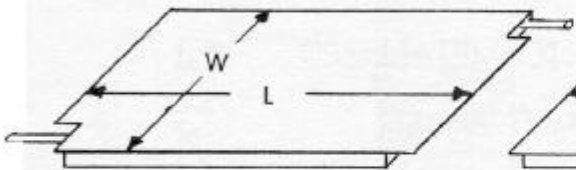

G

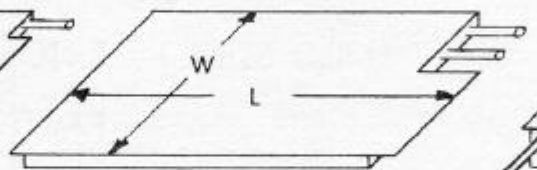

H

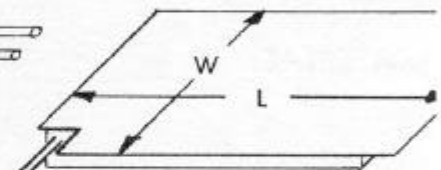

I

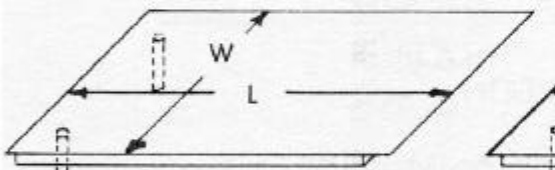

J

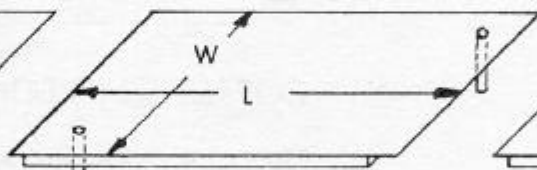

K

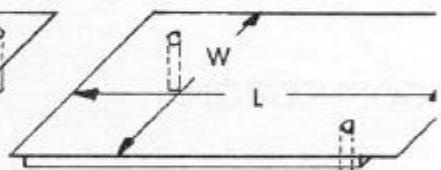

L

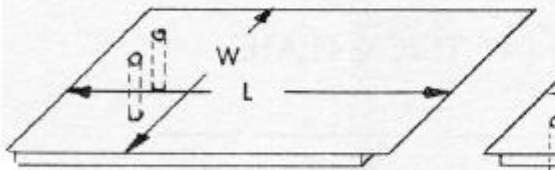

M

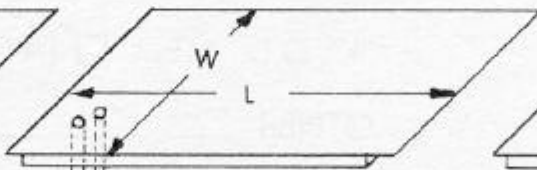

N

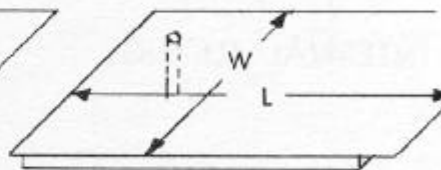

O

OTHER FITTING LOCATIONS AVAILABLE UPON REQUEST.
INDICATE ON SKETCH "P"

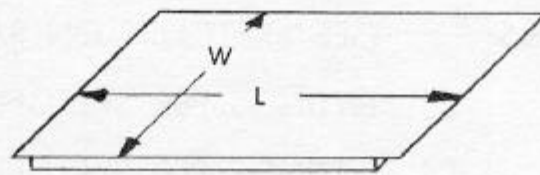

P

SALAD TYPE — IF DRAIN HOLE DESIRED, POSITION MUST BE INDICATED. SIDEWALLS AVAILABLE WITH STYLES 'J.' 'K.' 'L.' 'M.' 'N.' AND 'O' ONLY. INDICATE HEIGHT OF DEWALL