

# FREEZE-CELL

DOUBLE CONTACT FREEZING  
FOR FASTER FREEZING  
OF PACKAGED FOODS



# FREZE-CEL



**for faster  
freezing of  
packaged food**

- **High Production**
- **Efficient Operation**
- **Flexible Installation**
- **Rigid Construction**
- **Dole Patented "Thermo-Film"® Feature**
- **Aluminum Extruded Plates**
- **Special Square Tube Vacuum Cold Plates**
- **Pass Through Operation**
- **Available Less Cabinet for Multiple Installation**

## **Construction and Method of Operation**

Dole's Freze-Cel consists of a series of steel or aluminum extruded refrigerated plates which are enclosed in an insulated cabinet. As the plates are raised and lowered hydraulically, pressure is maintained on the packaged foods to ensure complete surface contact and to keep the packages flat and square. The product is placed on each of the plates or stations when in an "open" position. When all the packages are loaded, the plates are lowered with continuous pressure and the freezing process is begun.

The "Thermo-Film" plate which was pioneered and patented by the Dole Refrigerating Company is being used successfully by the entire food freezing industry. This exclusive feature provides an increase in freezing speed up to 10%. Made of two heavy gauge sheet steel surfaces, the plate affords perfect flatness on top and bottom and encloses a coil made of square steel tubing. A vacuum is drawn on the complete assembly so that the steel surfaces are forced against the tubing with a pressure of almost 1,000 pounds per square foot. This

pressure achieves a necessary bond between the freezing surfaces and the actual refrigeration coils. As the refrigerant is circulated through the tubing, heat is absorbed from the underside of the package above it and from the top side of the package immediately under it. This is "double contact freezing." The extruded aluminum plate is circuited to give optimum heat transfer over the entire freezing surface. Aluminum plate flat surfaces insure uniform flat packages after freezing.

Freze-Cel freezing units consist of two main parts, the freezing mechanism itself and the insulated cabinet. The freezing mechanism is mounted within one assembly and includes the plates, supporting framework, liquid and suction headers with flexible connections to the plates, and hydraulic cylinder. The insulated cabinet has doors on front and back which allow the "pass through" type operation which is both feasible and economically productive. These cabinets are constructed of a 4" core of rigid foamed plastic insulation faced both sides with 1/4" hardwood plywood faces. The polyester impregnated fiberglass cloth is the standard finish and is very tough, abrasion resistant, impervious to moisture and is sanitary. Dole's special construction results in a cabinet with substantial saving in weight, positive vapor proofing, and an attractive, permanent interior and exterior finish.

Although the cabinet is normally supplied, the freezing unit may be purchased alone if a number of freezers are being installed in one large enclosure or in an existing low temperature room.

The number of plates in the assembly determines the maximum space between the plates when the freezer is in its open or loading position. The thickness of the package to be frozen determines the closed space. Obviously, thinner packages allow the use of more plates, thereby increasing capacity. The maximum and

minimum openings for assemblies using various numbers of plates are found in the table on page 9.

Ammonia, the most commonly used refrigerant, may be fed to the plates through float valve and surge drum using gravity circulation. However, a liquid ammonia recirculating pump is more satisfactory since it works faster than gravity alone. The rapidly circulating refrigerant improves the heat transfer coefficient. Brine circulation may also be used. Freezers for use with Refrigerant R502 or R22 (full-flooded gravity type) are also available.

Available as an accessory, the hydraulic pumping unit is supplied in two sizes to handle multiples of freezers (see specifications on page 10). The hydraulic cylinder is 8" in diameter with a stroke adequate to allow maximum open spacing between plates. The plates are raised, lowered or held in an intermediate position by a 4-way valve. The cylinder and valve are included as a part of the freezer. A safety feature is incorporated to prevent excessive pressure build-up in the hydraulic system due to expansion of the food package during freezing.

The normal freezing operation consists of placing the packages to be frozen on a metal tray and placing this tray on one of the plates. The usual refrigerant temperature is about  $-30^{\circ}$  and on this basis, a 1" package is frozen in minutes or less. The capacity of the freezer depends on the number of trays which can be placed on each individual plate. The tonnage of the compressor required will also vary in accordance with the product being frozen and the thickness of the package. Freezer capacity and refrigerant tonnage required are shown on the tables on page 8.

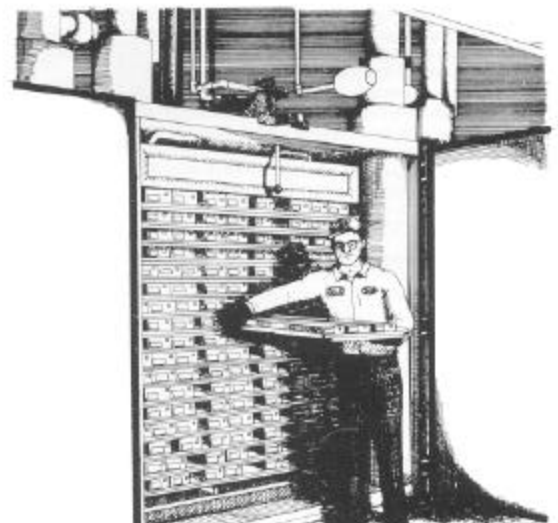
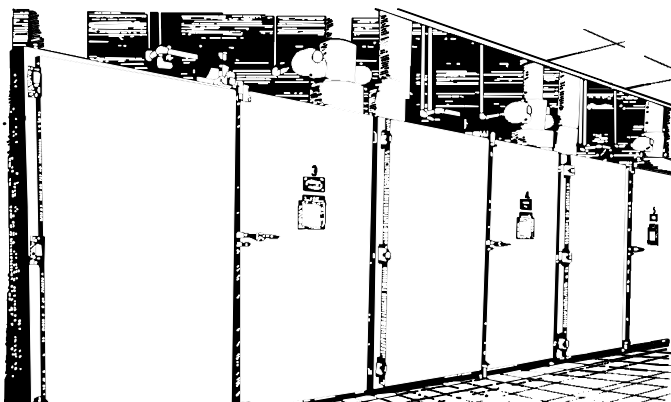

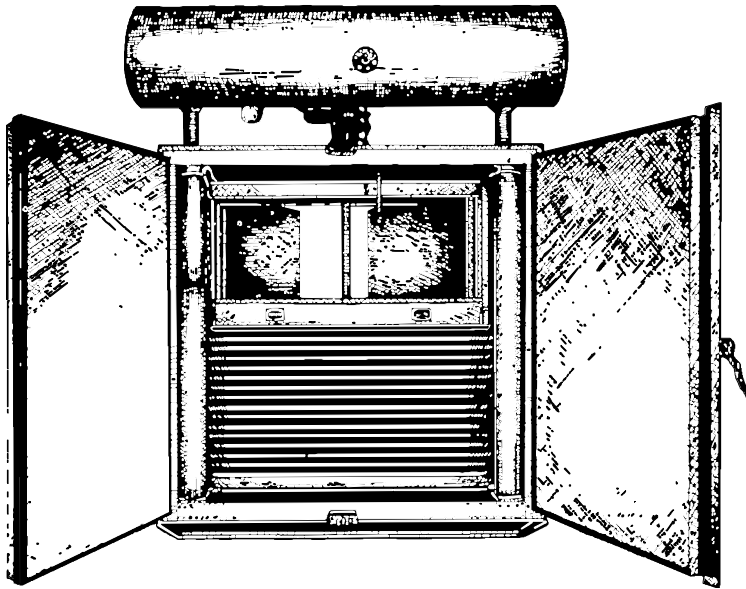

**FRONT VIEW  
SHOWING PLATES LOWERED  
IN FREEZING POSITION**  
(SURGE DRUM IS OPTIONAL EQUIPMENT)

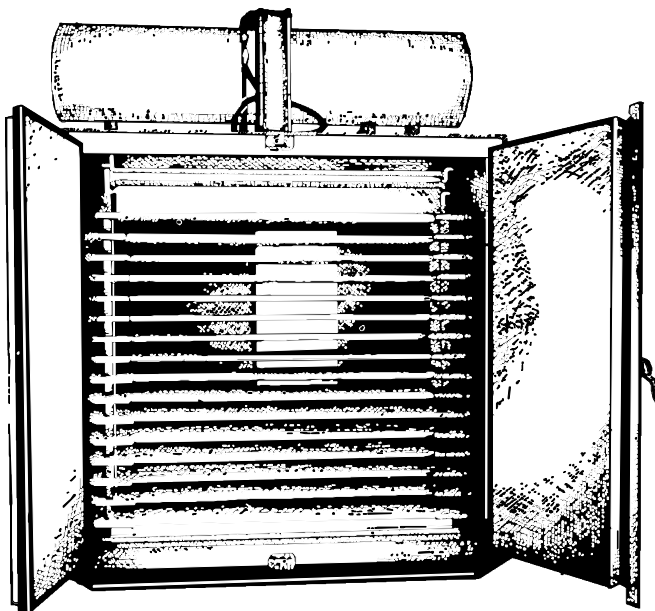

**REAR VIEW  
SHOWING PLATES RAISED  
FOR LOADING**

# Frame and Freezer Plate Assembly

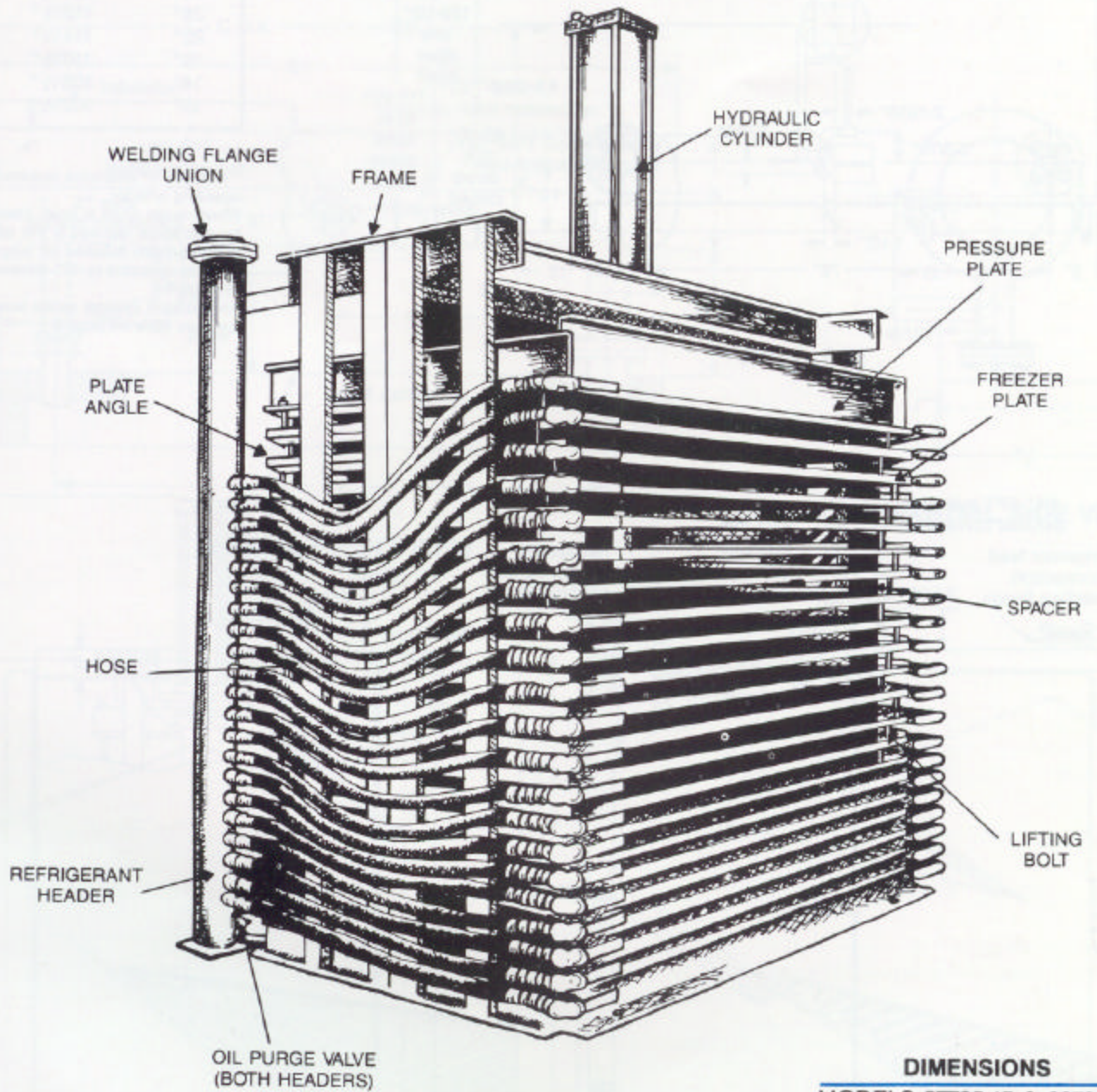

## DIMENSIONS

MODELS 57725-15 & 60725-1

Height	Overall*	123 1/2"
	Frame	81 1/2"
Width Overall		87 1/8"
Depth Overall		71 1/2"

\*Includes 1" clearance required for mounting cylinder

# Dimensional Specifications: Models 57725 (Steel Plate) & 60725 (Aluminum Plate)

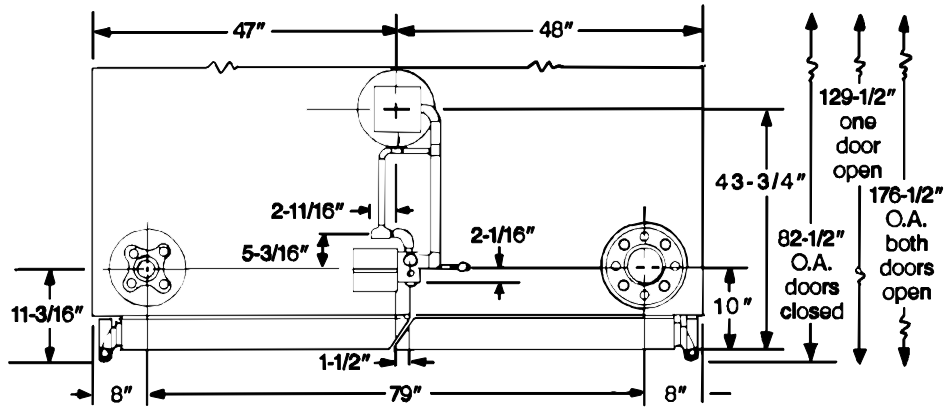

**TOP VIEW**

Hydraulic cylinder stroke	* "H"
38"	130½"
34"	126½"
30"	122½"
26"	118½"
22"	114½"
18"	110½"
14"	106½"
10"	102½"

\* Includes 1" clearance required for mounting cylinder.  
 Where surge drum is used, check the headroom required in this table with headroom required for surge drum as indicated in "D" dimension on page 7.  
 For hydraulic cylinder stroke selection, see table on page 9.

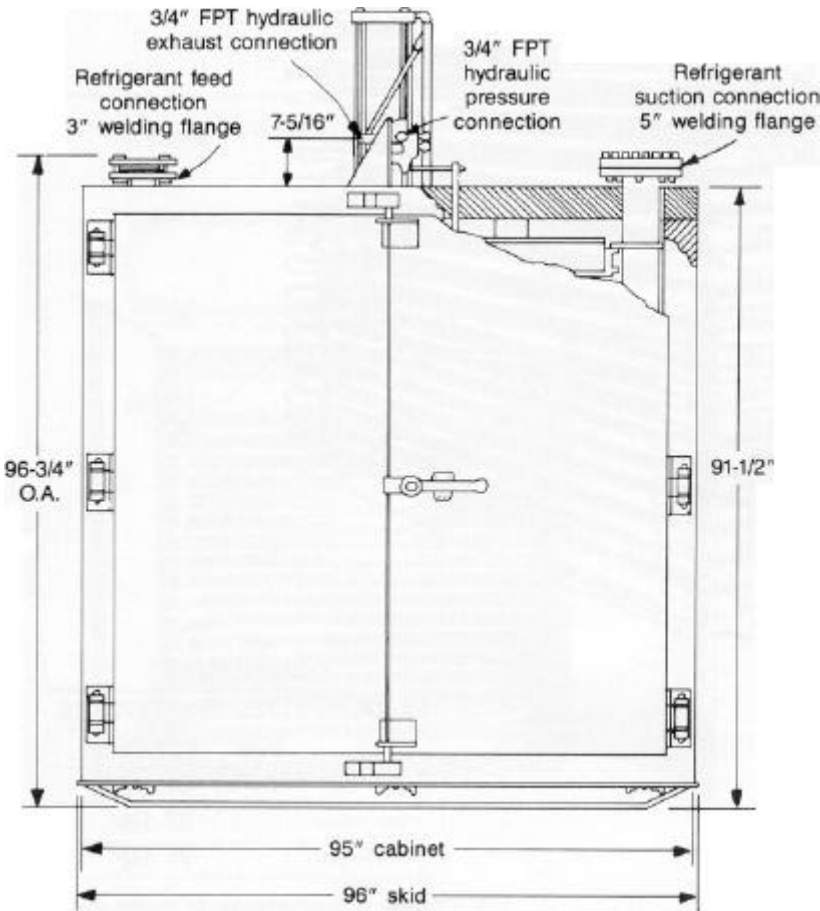

**FRONT VIEW**

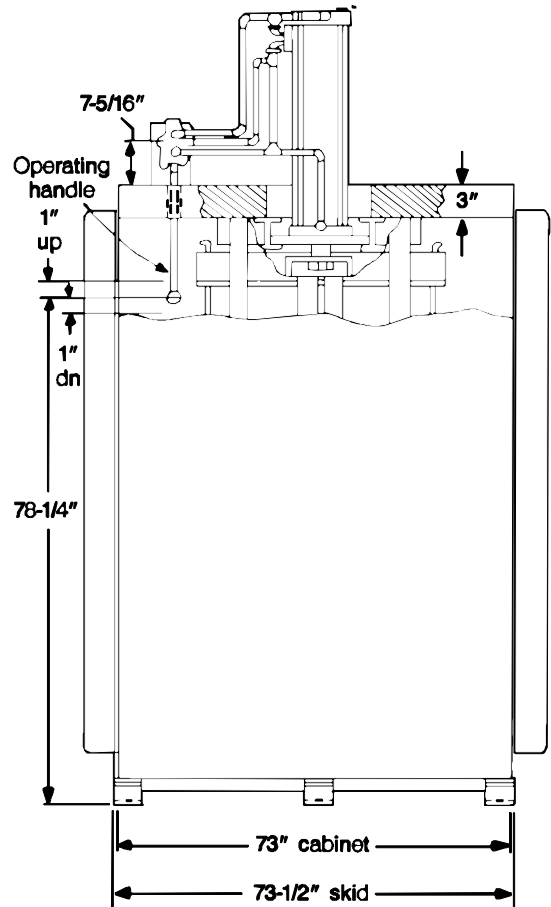

**SIDE VIEW**

# Double Contact Plate Freezers



## Insulated surge drum for ammonia gravity feed full flooded system (Including float valve and strainer)

No. of stations	A	B	C	D	E	F	G
7 thru 16	18"	100"	108"	130"	21"	25 1/2"	15"
17 thru 21	20"	101"	109"	132"	21 1/2"	26 1/2"	16"
22 thru 24	24"	103"	111"	136"	22 1/2"	28 1/2"	16"

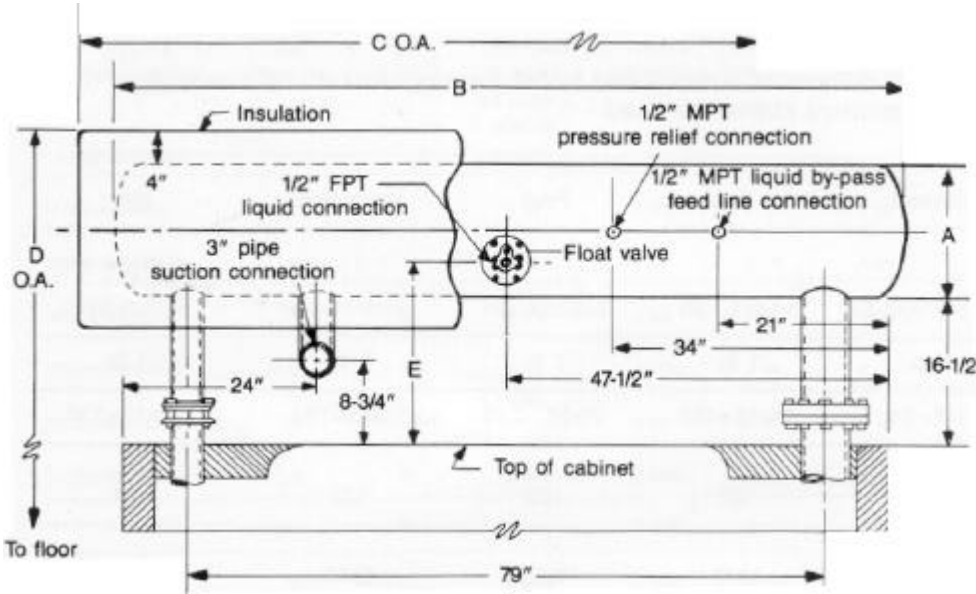

**PARTIAL FRONT VIEW**

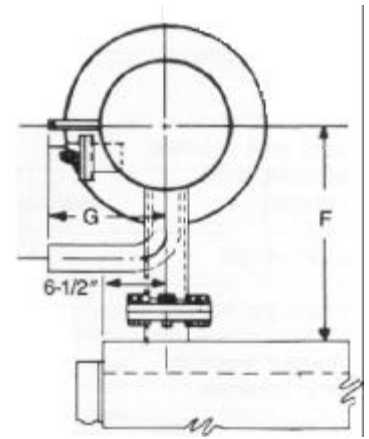

**PARTIAL SIDE VIEW**

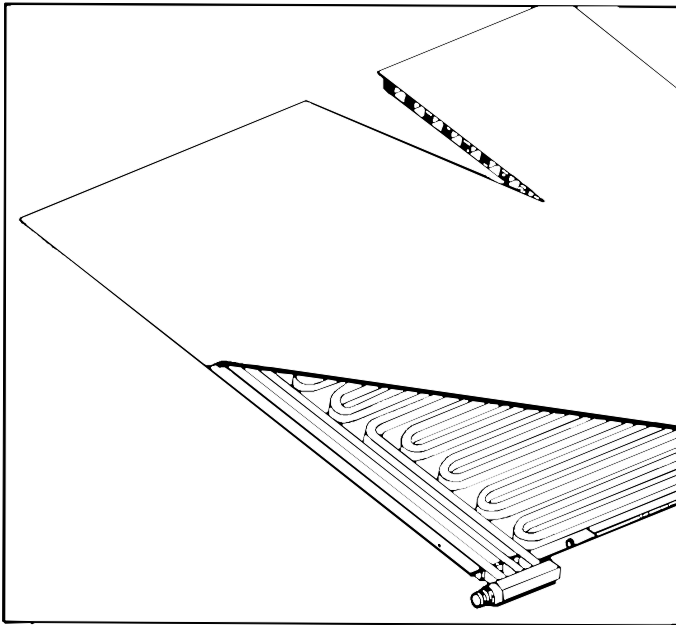

**STEEL PLATE CUT-AWAY VIEW**

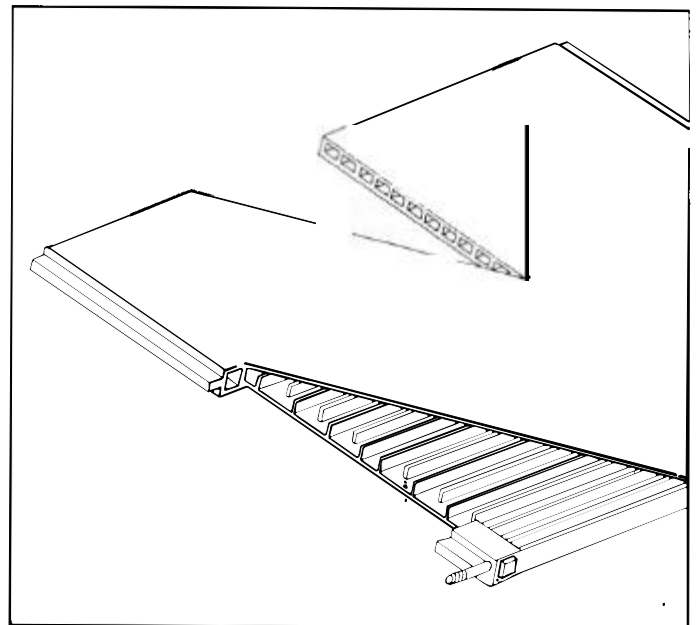

**ALUMINUM PLATE CUT-AWAY VIEW**

# Selecting the correct FREZE-CEL for your freezing operation

## Typical freezing capacity and tonnage requirements for Standard Model 57725-15, 15 station, 16 steel plate Freze-Cel with 57" x 72½" net freezing area per station, or Model 60725-15, 15 station, 16 aluminum plate Freze-Cel with 60" x 72½" net freezing area per station.

Capacities for other models are proportional to number of stations and to net freezing area of stations if other than standard plates are used.

Product	Fish	Shrimp	Cut Poultry	Fruit	Vegetable	Beef
Carton size - inches (last number is thickness)	8-3/4x3-1/4x1-1/8	11-1/2x6-1/4x2-3/4	5-1/4x4x1-3/4	5x3-1/2x1-3/4	5-1/4x4x1-3/4	5-3/8x5-3/8x1
Carton weight	1 lb.	5 lb.	1 lb.	1 lb.	1 lb.	1 lb.
Cartons per station	17x8=136	9x6=54	14x13=182	11x20=220	14x13=182	10x13=130
Estimated freezing time in minutes	68	257	122	122	122	60
*Freezing capacity Lbs/Hr	1800	945	1343	1623	1343	1950
Average BTU/Lb 50° to 0°	146	150	134	153	156	128
**Compressor capacity required tons refrigeration	27.38	14.77	18.75	25.87	21.82	26.0

\*Freezing capacity is based on product frozen from 50° to 0°F core. Loading and unloading times not included. Certain products, such as prepared dinners, pies, some vegetables etc., will require less compressor capacity due to lower weight concentration per station. Freezing time may increase for packages where air space is present as these voids reduce direct contact with the product.

Thickness and type of packaging material may also affect freezing time. Values given above are based on full package using standard paperboard carton with wax paper overwrap.

For estimates on equipment required, submit package size and weight, type of product and desired hourly production.

\*\*Compressor tonnage requirements include 25% for miscellaneous losses and are calculated at minus 30°F ammonia temperature at the plates.

### Estimated freezing times for various package thicknesses

Package thickness	Approximate freezing time (minutes)
1"	60
1-1/4"	77
1-1/2"	97
1-3/4"	122
2"	150
2-1/2"	217
3"	300

## Maximum and minimum openings between plates

Steel Plate size: 58-1/2 x 74-1/2 x 7/8"  
 Net freezing area: 57 x 72-1/2"  
 Aluminum Plate size: 60 1/2" x 74 3/4" x 7/8"  
 Net freezing area: 60" x 72 1/2"  
 \*Other plate sizes available on special order.  
 For example, 48" x 72 1/2" Aluminum

FREEZE-CEL MODEL NUMBER	NUMBER OF STATIONS	NUMBER OF PLATES	NOMINAL MAXIMUM OPENING STROKE BETWEEN PLATES, INCHES	NOMINAL MINIMUM OPENING BETWEEN PLATES — INCHES								
				10" CYLINDER STROKE	14" CYLINDER STROKE	18" CYLINDER STROKE	22" CYLINDER STROKE	26" CYLINDER STROKE	30" CYLINDER STROKE	34" CYLINDER STROKE	38" CYLINDER STROKE	
57725-9/60725-9	9	10	3 1/2	2 7/16	2	1 1/2	1 1/16	1				
57725-10/60725-10	10	11	3 1/2	2 1/2	2 1/8	1 3/4	1 5/16	1				
57725-11/60725-11	11	12	3 1/2	2 5/8	2 1/4	1 7/8	1 1/2	1 3/16				
57725-12/60725-12	12	13	3 1/2	2 11/16	2 1/4		1 11/16	1 3/8				
57725-13/60725-13	13	14	3 1/2	2 3/4	2 7/16	2 1/8	1 13/16	1 1/2	1 1/4			
57725-14/60725-14	14	15	3 1/2	2 13/16	2 1/2	2 1/4	1 15/16	1 11/16	1 3/8	1 1/8	1	
57725-15/60725-15	15	16	3 1/2	2 15/16	2 11/16	2 3/8	2 1/8	1 7/8	1 5/8	1 5/16	1	
57725-16/60725-16	16	17	3 3/16	2 11/16	2 7/16	2 3/16	1 15/16	1 11/16	1 7/16	1 3/16	1	
57725-17/60725-17	17	18	2 15/16	2 1/2	2 1/4	2	1 13/16	1 9/16	1 5/16	1 1/16	1	
57725-18/60725-18	18	19	2 3/4	2 5/16	2 1/16	1 7/8	1 5/8	1 7/16	1 3/16	1		
57725-19/60725-19	19	20	2 9/16	2 1/8	1 15/16	1 3/4	1 1/2	1 5/16	1 1/16	1		
57725-20/60725-20	20	21	2 3/8	2	1 13/16	1 9/16	1 3/8	1 3/16	1			
57725-21/60725-21	21	22	2 3/16	1 7/8	1 11/16	1 1/2	1 1/4	1 1/16				
57725-22/60725-22	22	23	2 1/16	1 3/4	1 9/16	1 3/8	1 3/16	1				
57725-23/60725-23	23	24	1 15/16	1 5/8	1 7/16	1 1/4	1 1/8	1				
57725-24/60725-24	24	25	1 13/16	1 1/2	1 3/8	1 3/16	1					

Standard Freze-Cel model is indicated in blue.

\*These freezer models are also available with maximum/minimum spacings other than those indicated; up to and including the following:

MODEL	MAXIMUM	MINIMUM
57725-9 60725-9	6 7/16"	2 1/16"
57725-10 60725-10	5 11/16"	1 13/16"
57725-11 60725-11	5 1/8"	1 9/16"
57725-12 60725-12	4 5/8"	1 7/16"
57725-13 60725-13	4 3/16"	1 1/4"
57725-14 60725-14	3 13/16"	1 3/16"

Maximum opening should be at least 3/8" greater than thickness of thickest package. Spacing between plates during freezing cycle is the thickness of package being frozen, plus thickness of material of trays, if trays are used. This dimension must be equal to or greater than the "nominal minimum opening" in above table, under various cylinder strokes. Having determined length of cylinder stroke, headroom required to accommodate freezer is found from table on page 6. If desired, a freezer can be arranged to accommodate packages of different thicknesses in the same loading. Submit dimensions and required hourly production of each different package for recommendations.

## Insulated Cabinets

**Outer Shell:** 1/8" thick, molded fiberglass reinforced with polyester resin, white gel coat finish (1)

**Interior:** 3/4" and 1 1/4" thick plywood edge framing (2) and 1/8" thick masonite face sheets (3)

**Insulation:** Poured-in-place fluorcarbon expanded rigid urethane foam; k=0.13 BTU in/hr sq. ft. °F (4)

**Hardware:** Heavy duty hinges and cam-latches attached to steel plates (5)

**Heater:** Steel tube with heater cable (6)

**Base:** Permanent structural steel skid, with leveling bolts

## Freezer Plate and Frame Assembly

**Frame and Pressure Plate:** All welded, structural steel construction, heavy zinc metallized

**Freezer Plates:** Dole's exclusive "Thermo-Film" vacuum plates consisting of square steel refrigerant tubing, bent on 2" centers, enclosed in heavy gauge steel casing finished in extra heavy metallized zinc

**Refrigerant Headers:** Specially designed to provide efficient refrigerant distribution. All welded construction with heavy metallized zinc. Liquid Connection—3" welding flange union. Suction connection—5" welding flange union

**Hoses:** Durable stainless steel hoses developed and industry approved for ammonia application. Fittings permanently assembled to hose. Orifices supplied in liquid feed to insure proper refrigerant distribution for forced re-circulating system

**Spacers:** Made of Benelex, a dense material impervious to moisture and mold. Location allows full use of plate freezing surface and provides for operating pressures to be transmitted from spacer to spacer. Spacers fastened by wing nuts for quick interchangeability. One complete set supplied for one inch (1") minimum spacing between plates unless otherwise specified

**Lifting Bolts:** Stainless steel for maximum resistance to abrasion and corrosion. Equipped with locknuts for fixed plate spacing

**Plate Angles:** Support plates directly along entire depth. Equipped with knockout type corrosion resistant guide pins to control vertical motion of plates.

## Hydraulic System

**Cylinder:** 8" diameter— double acting, brass cylinder body, steel mountings and heads. One piece cast iron piston with 2 1/2" diameter, hard chrome-plated piston rod. Rated at 350 psi

**Control Valve:** Four-way, three position, closed center spool, fully balanced, plunger type, rated up to 1500 psi. Built-in check valve and relief valve. Hardened and chrome plated spool

**Control Valve Handle:** Non-heat transferring plastic, conveniently located inside cabinet

**Pressure Build-up Safety Valve:** Consists of pressure relief valve arrangement to prevent possible excessive pressure build-up in cylinder due to expansion of food packages in freezing

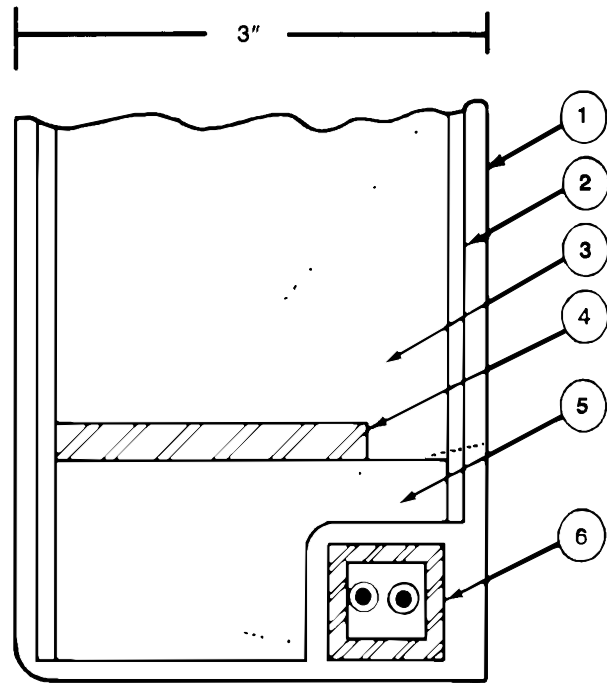

## Optional Equipment

**Hydraulic Power Unit Assembly:** Consists of motor, pump and tank, including pressure relief valve adjusted to 250 psi operation and gauge with shut-off valve, oil filter, strainer, air breather and oil level gauge; designed for continuous operation. 3-phase 220/440 V A.C. motor supplied unless otherwise specified. Motor starter is included. Available in two models as follows:

	MODEL A	MODEL B
Number of freezers handled	up to 4	up to 6
Operating pressure	250 psi	250 psi
Pump capacity	6.0 gpm	9.3 gpm
Motor horsepower	1 1/2 H.P.	2 H.P.
Tank capacity	30 gal.	50 gal.

**Surge Drum and Float Valve Assembly:** Surge drum ASME Certified, sized in accordance with Freze-Cel capacity. Insulated with 4" poured-in-place polyurethane foam inside of a white fiberglass reinforced polyester jacket. Equipped with low side float and strainer. Connections: 3" MPT suction, 1/2" FPT liquid, 1/2" MPT relief and 1/2" MPT liquid by-pass. All connections conveniently located on one side below top of surge drum.

\*NOTE: Freezing pans are not supplied as standard equipment.

Specifications subject to change without notice.

## Insulated Cabinets

**Outer Shell:** 1/8" thick, molded fiberglass reinforced with polyester resin, white gel coat finish (1)

**Interior:** 3/4" and 1 1/4" thick plywood edge framing (2) and 1/8" thick masonite face sheets (3)

**Insulation:** Poured-in-place fluorocarbon expanded rigid urethane foam; k=0.13 BTU in/hr sq. ft. °F (4)

**Hardware:** Heavy duty hinges and cam-latches attached to steel plates (5)

**Heater:** Steel tube with heater cable (6)

**Base:** Permanent structural steel skid, with leveling bolts

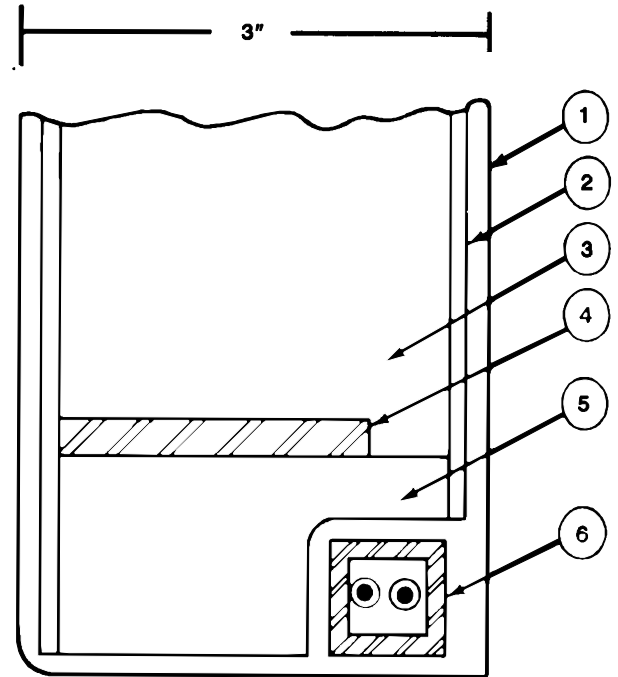

## Freezer Plate and Frame Assembly

**Frame and Pressure Plate:** All welded, structural steel construction, heavy zinc metallized

**Freezer Plates:** Dole's exclusive extruded aluminum plates with refrigerant circuiting for optimum heat transfer over entire freezing surface. Extremely flat surfaces for complete total product contact with freezing surface and insures flat packages.

**Refrigerant Headers:** Specially designed to provide efficient refrigerant distribution. All welded construction with heavy metallized zinc. Liquid Connection—3" welding flange union. Suction connection—5" welding flange union

**Hoses:** Durable stainless steel hoses developed and industry approved for ammonia application. Fittings permanently assembled to hose. Orifices supplied in liquid feed to insure proper refrigerant distribution for forced re-circulating system

**Spacers:** Made of Benelex, a dense material impervious to moisture and mold. Location allows full use of plate freezing surface and provides for operating pressures to be transmitted from spacer to spacer. Spacers fastened by wing nuts for quick interchangeability. One complete set supplied for one inch (1") minimum spacing between plates unless otherwise specified

**Lifting Bolts:** Stainless steel for maximum resistance to abrasion and corrosion. Equipped with locknuts for fixed plate spacing

**Plate Angles:** Support plates directly along entire depth. Equipped with knockout type corrosion resistant guide pins to control vertical motion of plates.

## Hydraulic System

**Cylinder:** 8" diameter— double acting, brass cylinder body, steel mountings and heads. One piece cast iron piston with 2 1/2" diameter, hard chrome-plated piston rod. Rated at 350 psi

**Control Valve:** Four-way, three position, closed center spool, fully balanced, plunger type, rated up to 1500 psi. Built-in check valve and relief valve. Hardened and chrome plated spool

**Control Valve Handle:** Non-heat transferring plastic, conveniently located inside cabinet

**Pressure Build-up Safety Valve:** Consists of pressure relief valve arrangement to prevent possible excessive pressure build-up in cylinder due to expansion of food packages in freezing

## Optional Equipment

**Hydraulic Power Unit Assembly:** Consists of motor, pump and tank, including pressure relief valve adjusted to 250 psi operation and gauge with shut-off valve, oil filter, strainer, air breather and oil level gauge; designed for continuous operation. 3-phase 220/440 V A.C. motor supplied unless otherwise specified. Motor starter is included. Available in two models as follows:

	MODEL A	MODEL B
Number of freezers handled	up to 4	up to 6
Operating pressure	250 psi	250 psi
Pump capacity	6.0 gpm	9.3 gpm
Motor horsepower	1 1/2 H.P.	2 H.P.
Tank capacity	30 gal.	50 gal.

**Surge Drum and Float Valve Assembly:** Surge drum ASME Certified, sized in accordance with Freze-Cel capacity. Insulated with 4" poured-in-place polyurethane foam inside of a white fiberglass reinforced polyester jacket. Equipped with low side float and strainer. Connections: 3" MPT suction, 1/2" FPT liquid, 1/2" MPT relief and 1/2" MPT liquid by-pass. All connections conveniently located on one side below top of surge drum.

\*NOTE: Freezing pans are not supplied as standard equipment.

Specifications subject to change without notice.

PRINTED IN U.S.A.

CATALOG FE — MODEL 57725 (STEEL)  
MODEL 60725 (ALUMINUM)



**DOLE REFRIGERATING COMPANY**  
1420 HIGGS ROAD • LEWISBURG, TN 37091

Dole's COLD LINE 1-800-251-8990

FAX 931 359 8664

Catalog FE